

MODERATE CONFIGURATION | ALUMINUM

SPECIFICATIONS

Overview

- Provides outstanding cooling power
- Omnidirectional
- Recommended airspeed range: 200 to 1,000 LFM (1 to 5 m/s)
- RoHS compliant

Technical

- Material: Pure Aluminum
- Mfg. process: Cold forging
- Plating options: Black/clear anodize, chemical conversion coating
- Base finish: Lapped
Flatness: Better than 0.001 in/in
Surface roughness: 16 RMS

Attachment Methods

- Mechanical clips (straight & diagonal)
- Double sided thermal tape
- Attachment tabs
- Push pins
- Holes & threads

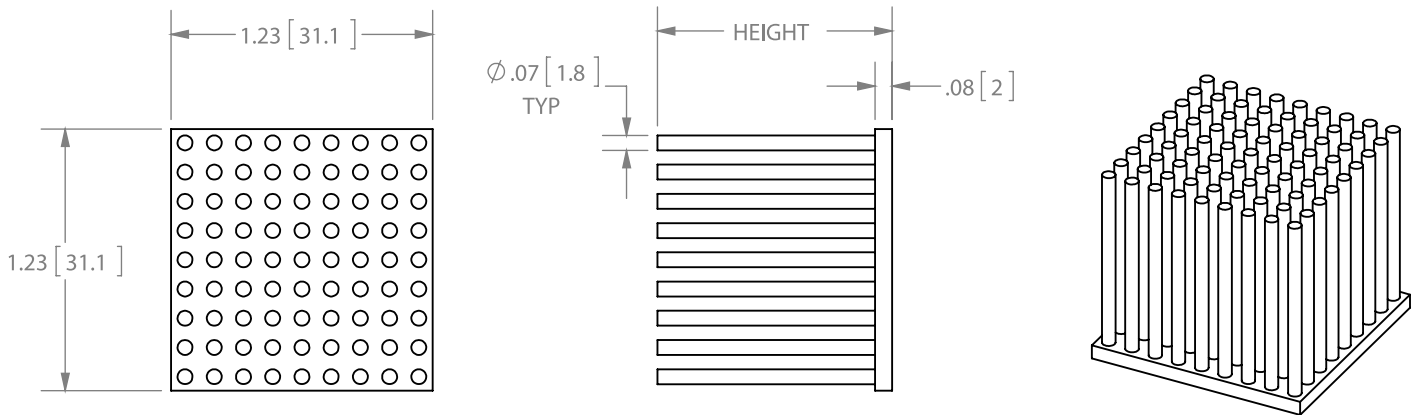

A FLEXIBLE APPROACH: Parts can easily be modified to fit any application

P/N	Height in(mm)	Weight lb(g)	Thermal Resistance in °C/W			
			200(1)*	400(2)	600(3)	800(4)
3-121202U	0.20(5.1)	0.015(7.0)	11.6	7.34	5.39	4.27
3-121203U	0.30(7.6)	0.018(8.4)	7.40	4.44	3.19	2.50
3-121204U	0.40(10.2)	0.021(9.7)	5.46	3.20	2.28	1.79
3-121205U	0.50(12.7)	0.024(11)	4.35	2.51	1.79	1.40
3-121206U	0.60(15.2)	0.028(12)	3.62	2.08	1.48	1.16
3-121207U	0.70(17.8)	0.031(14)	3.11	1.78	1.27	1.00
3-121208U	0.80(20.3)	0.034(15)	2.72	1.55	1.11	0.88
3-121209U	0.90(22.9)	0.037(17)	2.43	1.39	0.99	0.79
3-121210U	1.00(25.4)	0.040(18)	2.20	1.25	0.90	0.72
3-121211U	1.10(27.9)	0.043(19)	2.00	1.14	0.83	0.66